



Torque Motors

ETEL

ABOUT ETEL TORQUE MOTORS

Over the last 30 years, direct drive torque motors have provided significant performance improvements in numerous applications covering a wide range of high-tech industries. Today, direct drive technology is recognized as a leading solution towards meeting the requirements of high productivity, improved accuracy, and increased dynamics of modern machinery.

Direct drive essentially means the load and motor are directly connected without any intermediate gear train. Significant improvement to stiffness and a more compact solution are among the benefits of this technology. In addition to providing high dynamic performance, torque motors reduce cost of ownership, simplify the design of the machine and eliminate wear and maintenance.

Since its founding in 1974, ETEL has been exclusively dedicated to the development of direct drive technology. Through numerous innovations and patented designs, ETEL continues to provide unmatched torque efficiency for the most optimized designs.

Torque motor advantages

Key benefits inherent to the adoption of torque motor technology include:

- High dynamics
- High accuracy
- Optimal speed control
- Very compact design
- Outstanding MTBF
- Low maintenance

These advantages are further explained in the following pages.



What is a torque motor?

Torque motors are a special class of brushless permanent-magnet synchronous motors. Since the payload is directly connected to the rotor without the use of transmission elements, torque motors are classified as direct drives.

Depending on your perspective, a torque motor is either a rolled-up linear motor or a classic servodrive with a large number of poles. It is the large number of poles that enables conventional torque motors to attain high torque at moderate speeds. Another attractive feature is their compact design which includes a narrow lamination stack and a large hollow shaft or bore.

As with linear motors, torque motors are a type of "frameless" motor. This means that the motor does not include a housing, bearings, or feedback device. These components can be selected by the machine builder and optimized according to the required performance, or purchased as part of an assembly.

Torque motors produce high torque at moderate speeds and even when stationary. Contrary to traditional drives, the sizing and selection of a torque motor is purely based on torque, not power. Fundamentally, the peak torque determines the maximum torque that the motor physically produces and the continuous torque defines the amount of torque the motor can continuously supply. The duty cycle of the application will define the dependency on peak or continuous torque.

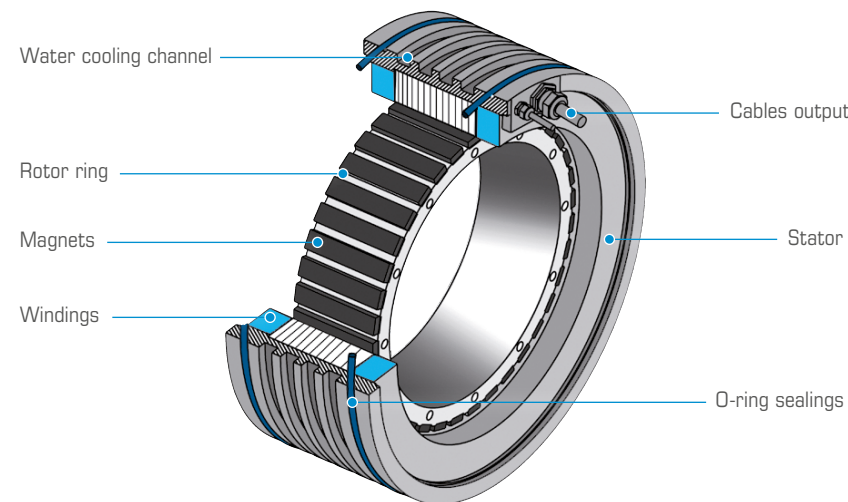

INDUSTRY SECTORS

Below are some examples of industry sectors where torque motors are successfully used, providing our customers in these areas with a distinct competitive advantage.



Machining



Finishing / grinding

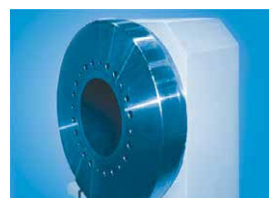

Tables / milling heads



Stamping / laser cutting



Electronics

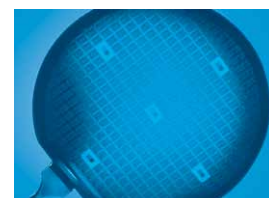

Semiconductor



Packaging



Printing / scanning



Telescopes



Robotics

WHY ADOPT TORQUE MOTORS?

Reduced cost of ownership

Direct coupling of the payload to the rotor eliminates the need for mechanical transmission elements such as gearboxes, timing belts, speed reducers and worm gear drives. And unlike brushed rotary motors, there is no contact between rotor and stator; therefore there is no mechanical wear resulting in excellent reliability and long lifetimes. Fewer mechanical parts also minimizes maintenance and reduces the system cost. The direct drive technology intrinsic to a torque motor system results in an efficient and effective gearless assembly.

Easy integration

ETEL's torque motors are available in a wide range of sizes and can be easily adapted to most applications. ETEL's unmatched standard product offering includes motors with external diameters from 140 mm to 1290 mm. The use of magnets and limited air gap results in a large hollow shaft or bore for easy integration of cables, cooling tubes, or other application related equipment. The ring-like configuration of a torque motor minimizes the volume required for mounting. This gives the machine designer great flexibility in locating the motor to work with bearings, feedback devices, and payload.

Dynamic performance

Dynamic performance is drastically improved by using direct drive due to the very high control loop bandwidth that can be achieved on the overall system. The direct coupling of the load and position feedback to the motor has the advantage of eliminating all phenomena that limit the dynamic performance on non direct driven machines. Eliminating long-time drift, elasticity, and backlash is a huge advantage for machine performance and lifetime.

Torque motor applications have a wide range of dynamic performance requirements. Depending on the specifics of a system's duty cycle, the peak torque, continuous torque, or both will drive the selection of a motor. An application with a light duty cycle that requires high peak torque for a short period of time will typically utilize an air cooled motor like ETEL's TML and TMM series. As the continuous torque requirement increases so will the temperature of the motor. The integrated liquid-cooling capability of the ETEL TMB+ and TMK motors provides an efficient means of temperature control ensuring high dynamic performance that can be maintained even for the most demanding applications.

Wide torque-speed range

Direct drive torque motors deliver high torque over a wide range of speed, from a standstill or low speed condition to high angular velocities. While torque motors can achieve high velocities (up to 5450 rpm), there is a trade-off in torque as the motor becomes limited by speed dependent losses increase. The performance of a torque motor over its velocity range is illustrated in its torque/speed curve. An example is shown opposite.

The torque motor is part of a complete direct drive solution which includes a position controller. High-end digital controllers like the ETEL position controllers, which have been designed specifically for direct drive applications provide excellent control loop quality ensuring optimum stiffness, smooth motion, and excellent velocity control with low torque ripple.

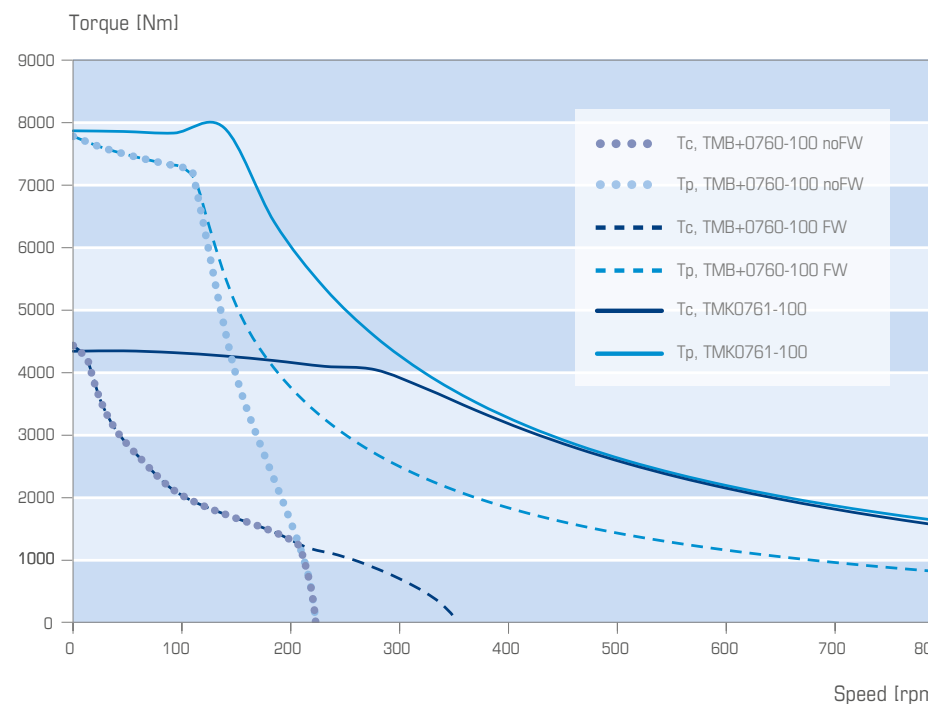
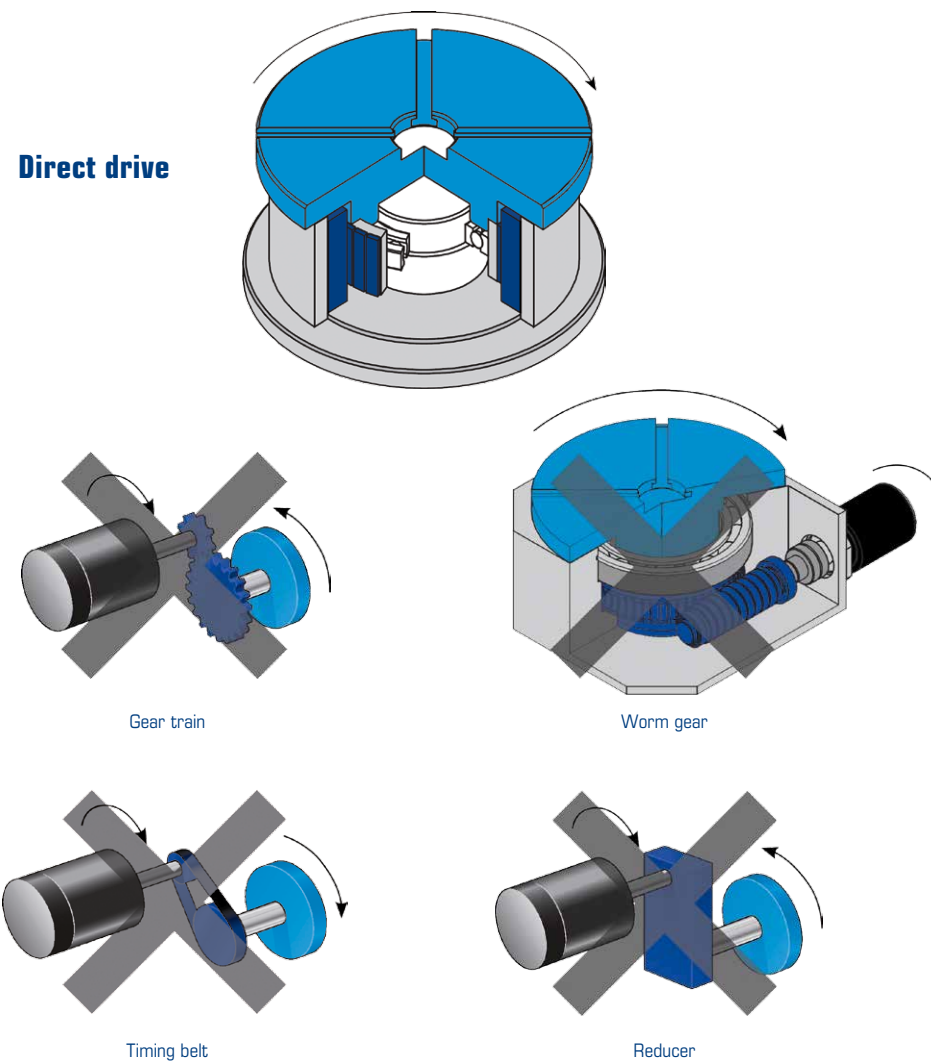

WHY CHOOSE ETEL?

Technology expertise

ETEL's know-how in ironcore design provides the industry's most efficient direct drive torque motors.

Unmatched performance

ETEL's design is well known in the worldwide direct drive market as a high performance product. For many years, the most high-end applications in the field have been driven by ETEL's motors. A continuous development effort maintains ETEL's leading position in the market.

Direct drive expertise

ETEL has been working strictly on direct drive technologies for more than 35 years. In addition to the motor technology know-how, through the years, ETEL has developed valuable knowledge about motion control by developing control electronics and fully integrated motion systems. Our deep understanding of the overall motion system helps us find the appropriate solution for our customers' needs.

High quality

High product quality is guaranteed by ETEL's use of modern development tools and thorough qualification procedures. All ETEL motors are manufactured in Switzerland according to highest quality standards.

Ease of integration

Compatibility of ETEL's torque motors with a wide range of control electronics results in easy integration of a direct drive solution.

Product range

With standard motors from 140 to 1290 mm in diameter and 38 to 42900 Nm of peak torque, ETEL offers the largest selection of torque motors on the market.

The majority of ETEL torque motors can be ordered with or without water cooling channels. Furthermore, different winding types are available to best fit our customers' applications.

TORQUE MOTORS

ETEL offers the most comprehensive standard torque motor range in the industry. With more than 100 models to choose from, almost any requirement can be successfully fulfilled. ETEL also excels in developing custom motors to meet a specific application need.

ETEL's TM series are the industry's most popular ironcore frameless torque motors. Powerful magnets are used to maximize torque and acceleration while minimizing the size of the motor. The performance of ETEL's torque motors have been further increased by the use of "buried magnet" technology on the latest TMK family.

The TMB motor series is today's industry preferred torque motor solution. This renowned family is designed with a precision stator and has been optimized to achieve very high continuous torque while minimizing the dissipated heat when liquid cooling is used. For more demanding applications, the TMK family can achieve more torque and significantly faster speeds than TMB+ motors thanks to its unique rotor design. In addition, the TML family can be used to reach high performance at a lower price in less demanding applications. All families of torque motors benefit from ETEL's know-how in ironcore design that provides unmatched torque efficiency and low torque ripple.



Torque motors range

ETEL offers the most comprehensive standard torque motor range in the industry. With more than 100 models to choose from, almost any requirement can be successfully fulfilled.

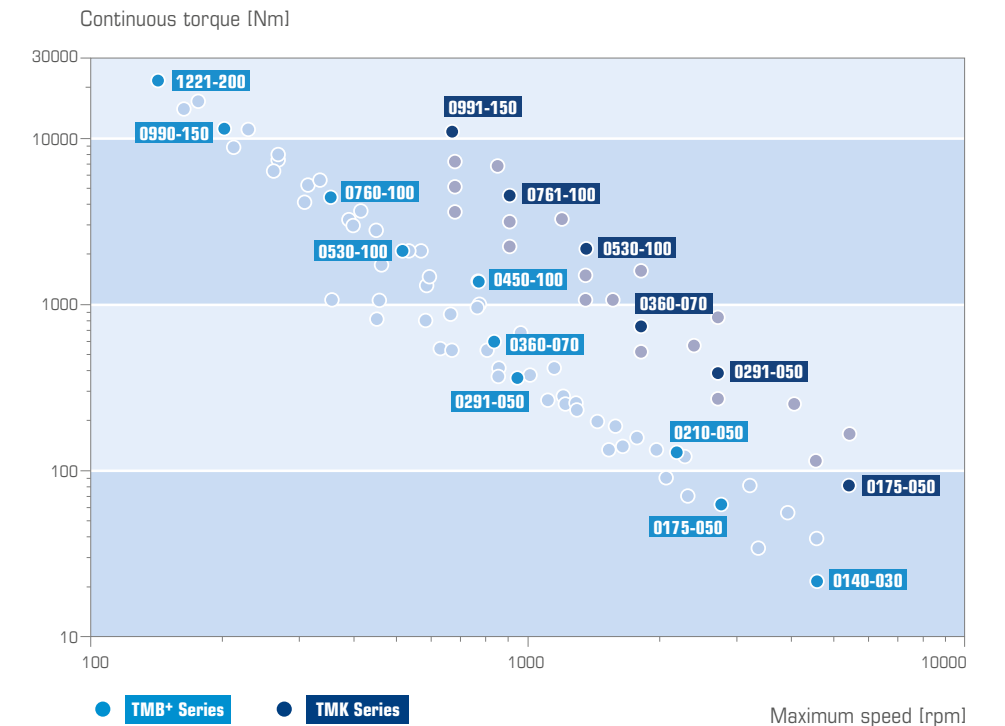

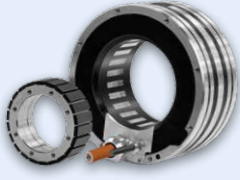
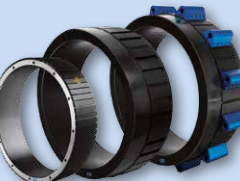
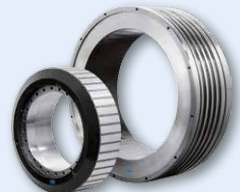
PERMANENT MAGNETS SYNCHRONOUS TORQUE MOTORS	CONVENTIONAL TORQUE MOTORS	
	CHARACTERISTICS	TYPE
	 <p>With cage</p> <ul style="list-style-type: none"> External diameter up to 1290 mm Large hollow shaft up to 1070 mm Peak torque up to 42900 Nm Maximum rated speed up to 4590 rpm Liquid cooling channels 	TMB+
	 <p>Without cage</p> <ul style="list-style-type: none"> External diameter up to 581 mm Large hollow shaft up to 420 mm Peak torque up to 4990 Nm Maximum rated speed up to 2600 rpm No liquid cooling option 	TML TMM
 <p>With cage</p> <ul style="list-style-type: none"> External diameter up to 1050 mm Large hollow shaft up to 800 mm Peak torque up to 20800 Nm Maximum rated speed up to 5450 rpm Liquid cooling channels 	TMK	
	HIGHLIGHTS	APPLICATIONS
	<ul style="list-style-type: none"> More than 60 standard sizes available 600 VDC bus voltage Very high continuous torque Very high peak torque Flux weakening compliant Low torque ripple Designed for the most demanding applications 	<ul style="list-style-type: none"> High speed milling / turning tables High precision machining centers Grinding / finishing machines Boring / drilling / tapping machines Milling heads Transfer lines EDM Laser / ultrasonic cutting machines Stamping machines Lathes Indexing tables Electronic chip testing equipment Pick-and-place machinery High-end printing / scanning machines Packaging equipment Handling equipment Composite materials manufacturing Telescopes
	<ul style="list-style-type: none"> Two fixing methods (TML & TMM) 600 VDC bus voltage Very high peak torque Low torque ripple Light weight 	
	<ul style="list-style-type: none"> Powerful high speed ironcore torque motor TMK stator (up to Ø530 mm) compatible with the mechanical interface of the TMB+ series 600 VDC bus voltage Continuous torque increased by up to 30% vs TMB Very high peak torque Up to 8 times speed increase vs TMB Flux weakening compliant Low torque ripple 	

TMB+ torque motors range

ETEL continuously strives to deliver the most top-of-the-line product on the market and the TMB+ is a further example of this. The TMB+ is fully pin-to-pin compatible with the worldwide known TMB series but offers an increased performance of up to 22% continuous torque, up to 4% on top of it is already high peak torque and power losses reduction can reach up to 30%.

With four different winding options per size and a new 200 mm active length for each diameter, the TMB+ increases its overall size selection from the TMB. These options help propel ETEL torque motors beyond the competition and pushes towards the goal of making direct drive technology as accessible as possible.

With 62 standard model sizes and four different windings each, the TMB+ allows the user to get the maximum performance depending on how much torque, current, and speed are required. TMB+ motors can achieve a peak torque of up to 42900 Nm and utilize flux weakening to increase its speed capabilities.

It also has the option of coming with ETEL's IMTHP thermal module which, when coupled with ETEL's torque motors, enables users to reduce their amount of safety margins while receiving precise and reliable temperature monitoring.

DIRECT DRIVE SOLUTION

To achieve optimum performance from a direct drive motor, it must be built to the necessary standards of precision and stiffness as part of a complete direct drive solution. In addition to the motor, the main key components of a direct drive system are the controllers, encoders, bearings and machine structure.

Controllers

The best torque motor performance is achieved when integrated with a fully digital controller with extremely high bandwidth capability like the ETEL AccurET position controllers family.

In a direct drive system, the controller can benefit from a very precise position feedback due to the fact that there is no transmission in between the feedback device and the load. Because of this high quality feedback signal, a high-end controller (such as ETEL's AccurET) can compute advanced control algorithms at a very high frequency. Ultimately, the precision and the dynamics of the axis are drastically increased.

Some key factors to be taken into account when selecting a controller are listed below:

- High frequency control loops (current, speed, and position loops).
- High current and position loop bandwidths (typically >2 kHz and >100 Hz respectively).
- High encoder interpolation factor to ensure adequate speed and position resolution.
- Advanced control algorithms (PID with feed-forward, state space regulators, observers, notch filters, etc).
- Advanced features: ability to compensate for cogging torque, stick slip, and other system repeatable phenomena.

ETEL's torque motors have been successfully integrated with most major brands of servo controllers and CNC including: HEIDENHAIN, Siemens, Fanuc, Bosch, B&R, Kollmorgen, and Num.



ETEL's AccurET/UltimET controller family is specially designed for a variety electronics and semiconductor related applications, where extremely high precision is needed without any compromise on throughput. They can provide:

- High position accuracy
- Close to zero settling time
- High dynamics
- Multi-axis interpolation
- Real-time communication bus
- And much more...

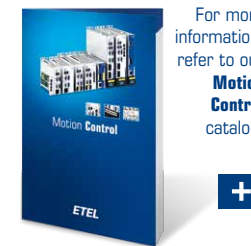

For more information, refer to our **Motion Control** catalog.

Encoders

Direct drives place rigorous demands on position-signal quality. Optimum measuring signals increase the quality of the machined workpiece surface, reduce vibration in the machine frame, stop excessive noise exposure from velocity-dependent motor sounds, and prevent additional heat generation in the motor.

Generally, ETEL recommends the use of encoders with optical scanning methods that provide benefits in the accuracy, speed stability, and thermal behavior of direct drive axes. Since there is no mechanical transmission between the encoder and the feed unit, the position encoder must have a correspondingly high resolution for precise velocity control at slow traversing speed.

A rough estimate to achieve good performance is 100 lines per pole. To achieve very high accuracy this value must be increased. Very high speed applications may require a lower line count to limit signal frequency. When combined with the interpolation capability of the electronics, resolutions of less than 1 arcsec can be achieved.



Picture courtesy of Dr J. HEIDENHAIN GmbH

ETEL experience with the test equipment for MEMS Sensors applications

ETEL are present in most of the critical stages of Integrated Circuit manufacturing processes. An interesting development of the IC is Micro Electro-Mechanical Systems (MEMS). MEMS devices are typically miniature IC devices that consist of a central processing unit and mechanical components that interact with the surroundings. MEMS devices generally range in size from 20 micrometers to a millimeter (0.02 to 1.0 mm). Examples of MEMS devices include microphones, accelerometers, gyroscopes and pressure sensors.

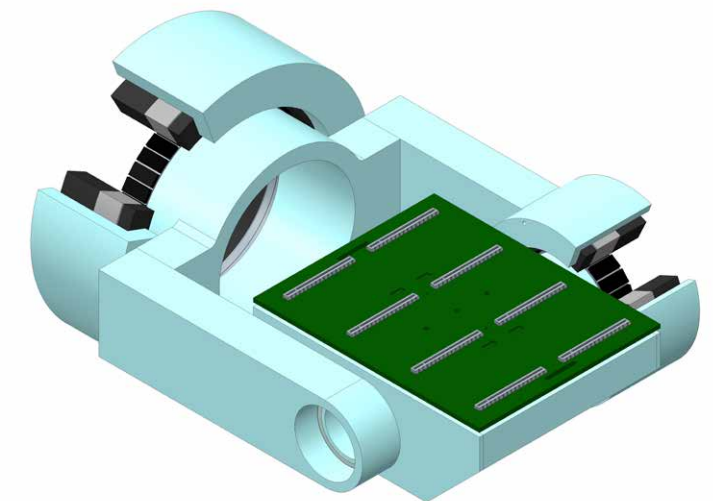

Test equipment for MEMS Sensors with integration of 2 torque motors

In addition to the standard inspection of ICs such as visual and electronic testing, MEMS devices also require a stimulus of the mechanical component(s) with extra consideration required when handling due to the fragile nature of the mechanical parts and the positional accuracy of the motors which must be greater than the accuracy tolerance of the components.

ETEL provide the best suited direct drive motors and controls that fulfill highly demanding MEMS stimulus unit applications helping our customers reach outstanding levels of machine performance with ETEL products such as:

- Torque motors and controllers that generate accurate reference motion profiles (constant speed / sine profile) for MEMS calibration.
- Torque motors and rotary tables that provide high speed indexing of components for optical testing.
- Linear motors and controllers that allow monitoring and control of acceleration for pick and place of extremely fragile MEMS devices.
- Linear motors that generate high accelerations of up to 25 g for shock and high-g testing.

By using ETEL direct drive motors and controllers that are providing the most advanced features currently available on the motion control market, our customers can reach extreme precision levels without compromise of the machine throughput.



Pictures courtesy of Dr J. HEIDENHAIN GmbH

TORQUE MOTOR SELECTION

Many factors must be taken into consideration when choosing a torque motor to ensure outstanding system performance. This brochure provides a basic overview of some of the key selection factors that should be taken into account when choosing a torque motor. For detailed calculation and sizing information, please refer to the ETEL torque motors integration manual, or ask an ETEL application and support engineer for assistance.

Motor sizing

The first step in a torque motor sizing is to define the torque and speed requirements for the application. The torque required for each move within the cycle can then be used to determine the continuous torque. When calculating the continuous torque it is important to consider all factors such as friction, machining torque, static force due to an offset load, and external perturbations.

Power dissipation of the motor is estimated calculating the continuous torque. The amount of heat produced by motor power dissipation will determine the temperature increase of the structure and if liquid cooling is required.

Under static conditions with an applied load, one motor phase can get disproportionately hot, because the power dissipation is not shared equally among all three phases. To ensure safe operation under these conditions a stall torque calculation should be performed.

ETEL's motors are available in several winding configurations. The winding should be chosen to match the speed requirements of the application and the voltage and current specifications of the electronics. Note that the torque/speed characteristics of a motor change with the winding.

Detent effects

Thanks to our technology know-how, ETEL has the expertise to manufacture ironcore torque motors with very low detent effects. Our design uses an innovative combination of open slots, orthocyclic windings and fractional pole pitch. This solution significantly reduces detent effects without any skewing of laminations or magnets which would result in lower torque density.

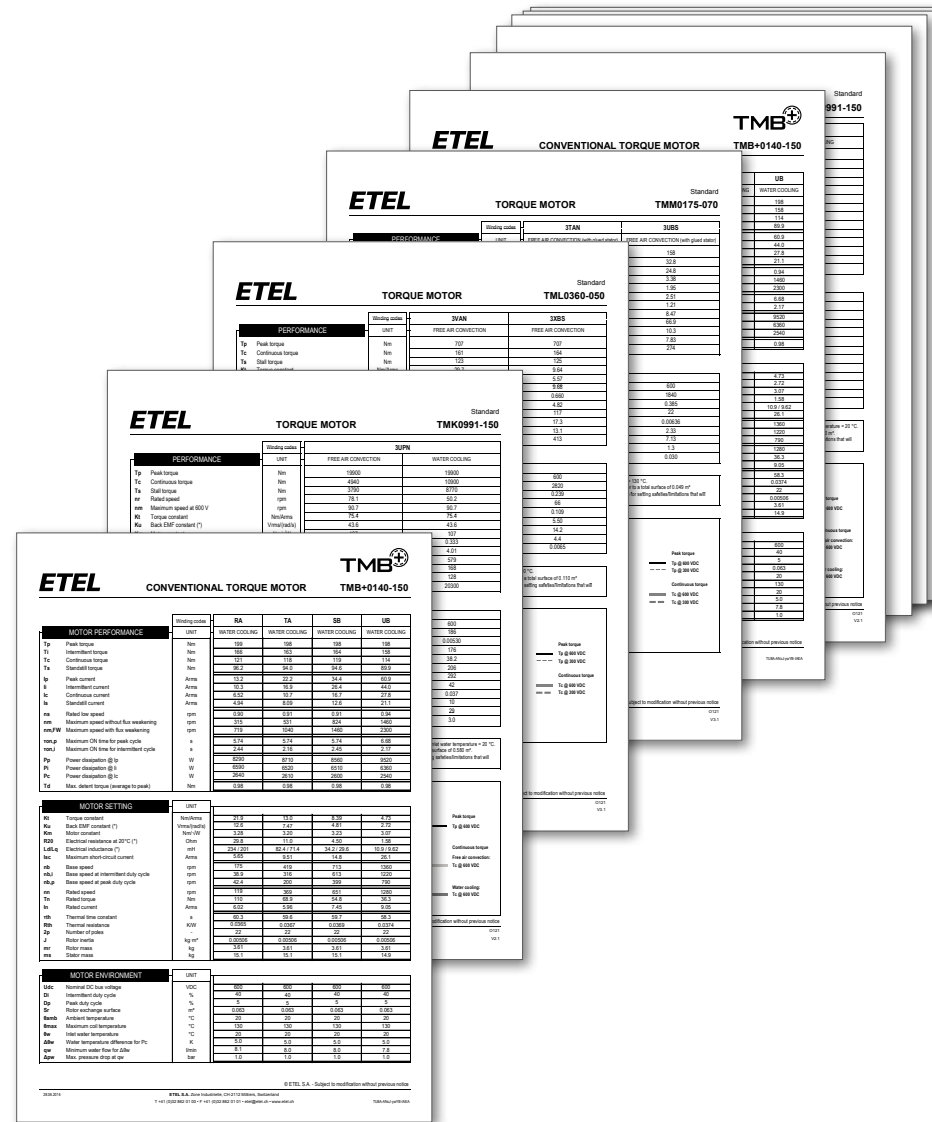

Motor constant

The motor constant, K_m , is one of the key parameters for comparing permanent magnet synchronous motors. It shows the relationship between torque produced and resulting power losses. A motor with a higher value of K_m is a more efficient generator of torque.

K_m is determined by the design and construction of the motor. This parameter is related to the internal design of the motor (copper filling factor, electromagnetic design, etc). Therefore, it is a better indicator of motor performance than the torque constant, K_t (Nm/Arms), which relates torque output to the supplied current. In ETEL motors, K_t can be easily adjusted by changing the winding type. K_t is useful for matching a motor to a servo amplifier, but it does not provide information about the motor's efficiency.

Thermal considerations

Like all servo motors, torque motors generate heat in operation. In order to reduce thermal expansion of the machine, this heat has to be removed as efficiently as possible. ETEL TMBs and TMKs torque motors provide optimized cooling channel design to ensure a maximum heat evacuation through the coolant. Keeping the machine structure cool is mandatory to reach high precision and repeatability levels.

Torque motors can be cooled either by free air convection or with a liquid coolant. Liquid cooling is recommended for demanding applications where coolant is available. Due to their optimized electromagnetic design, ETEL's torque motors produce much more torque for the same input power than competitive products.

On any direct drive application, the thermal management is of major importance and closely related to the final machine performance. In fact, in a direct drive axis, the motor is located very close to the working point. This is a big advantage in terms of mechanical stiffness and leads to unmatched machine performance. However, the fact that the motor is highly integrated also means that the heat generation is closer to the critical area than in a conventional worm gear system for example.

ETEL has a long experience in torque motor integration and heat management. Do not hesitate to contact your ETEL representative to get support during machine design.

Data sheets

ETEL torque motors information is available in the corresponding motors data sheets. They include the specifications, performance as well as the torque vs. speed curves of each standard ETEL motor. For more information about the torque motors or to download the data sheets, refer to our website: www.etel.ch



Integration manual

For more information on motor selection and integration, ask for the ETEL torque motors integration manual through the request form on our website or contact your corresponding ETEL representative.



ETEL sizing tool

ETEL has developed a powerful sizing tool that can simulate the customers' machine operation. It helps in achieving the very best "performance/price" ratio that can be obtained on your specific application. Do not hesitate to contact your ETEL representative for technical support during the machine design phase.

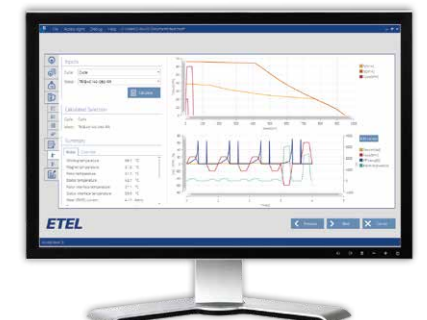

CASE STUDIES

ETEL motors in metrology application

Stringent requirements for precise gear measurements for increasingly complex drive components demand the best measuring technology available from machine and software optimized for such applications. The drive technology element used in such measuring machines must offer the highest performance such as that provided by ETEL. That's why leading gear manufacturers put their trust in precision measuring centers equipped with ETEL's direct drives.

At the heart of a precision measuring center is an accurate and durable rotary table with a torque motor drive from ETEL. ETEL's expertise in torque motor design results in very low cogging which leads to a very smooth motion, good speed stability and high position accuracy. In addition to its high efficiency motor design it is well-suited for thermal-drift sensitive precision machines. Configured as a measuring axis, it provides concentric seating of the workpieces to be tested.

In combination with the three linear measuring axes equipped with ETEL's compact linear motors, the measuring centers trace and inspect the functional surfaces of gears and general drive components in generator mode. ETEL's linear motor designs with the lowest force ripple allows for a very uniform motion and very precise positioning free of backlash, direct drive technology. This guarantees maximum measuring accuracy and reproducibility thanks to the high quality of the ETEL products.



Picture courtesy of Klingelberg GmbH

ETEL torque motors in rotary tables for 5-axis simultaneous machining

The leading manufacturers of roundtables have used ETEL torque motors in directly driven rotary axes since 1996. This can be typical single axis machines or biaxial and multi-axial combinations of roundtables, as are required in milling centers in the manufacturing of free-form surfaces.

As milling centers comprise more and more axes, a higher compactness and easier integration of the rotary motors are needed. ETEL's direct drive technology torque motor is an optimal solution. They offer a small form factor and high torque density without any additional transmission elements like gearboxes and allow an effective and direct integration below the payload.

Very often, free-form surfaces are required in the aerospace or energy technology components, where individual blades or whole turbines and compressor wheels are manufactured. Such niche parts require reliable machines which can be guaranteed with the high quality of the ETEL torque motors.

Since 2001 ETEL motors have been used in 2-axis rotary tilting tables – also known as rotation swinging bridge – in particular for the manufacturing of motor vehicle turbo components such as aluminum or titanium impellers. In some of these swinging bridges two ETEL motors are used and have to be aligned with each other. This can easily be realized thanks to ETEL's precise motor manufacturing as well as additional precise alignment feature on the motor which leads finally to a higher accuracy and efficiency of the machine.



Picture courtesy of Peiseler GMBH & Co. KG

TMB+ in high-end machine tool



Pictures courtesy of Liechti Engineering AG

To remain more competitive in the market, ETEL constantly improves its products. Some customers, using the well known TMB motor in the machine tool industry choose to update their machine with the latest TMB+ torque motor. The advantages of direct drive technology associated with the outstanding performance and reliability of ETEL products contributes to our customers' success.

In some applications such as aerospace or power generation, precision and quality are a "must" for component machining. When machining with 5- or 6-axis machines, the key criteria for productivity are stability, dynamics, and agile contouring capabilities. Meeting the specifications of the machine becomes

even more challenging when the materials to be machined are "difficult-to-cut" materials such as titanium or super-alloys. In this case, direct drive technology and more precisely ETEL's TMB+ motors play a major role in the overall machine performance.

The limited production related to this specific high-end market naturally defines some key factors such as flexibility, optimal performance and low cost of ownership. With 11 different motor diameters (from 160 mm to 1290 mm) the very wide range of TMB+ perfectly fits these kinds of applications where flexibility on standard products is needed with absolutely no trade-off of performance and quality.



Pictures courtesy of Liechti Engineering AG



Picture courtesy of Peiseler GMBH & Co. KG

Nickel-based alloys, such as Inconel or state-of-the-art alloys from titanium aluminide are machined on these machining centers as components, in aircraft and gas turbines. For this purpose the wide torque-speed range of ETEL's torque motors offer the right solution.

These applications have high demands concerning the surface quality and shape accuracy of the workpieces therefore a good axes design with the ETEL torque motors must have a high control stiffness and the highest dynamics. In particular the ETEL's expertise in the design of very low cogging motors allows for unmatched performance of the machine.

It is important to bear in mind that even these highly stressed precision parts are subject to commercial pressure and as a result manufacturers strive for low unit costs, which is made possible by the flexible longevity and high processing speeds, when using ETEL torque motors.

CASE STUDIES

Large TMKs enable milling / turning features

When machining large components, it has always been important to balance the positioning needs requiring high torque with low speed and high speed with low torque for the dynamic mode.

The milling/turning machines equipped with ETEL TMK motors constitute a real technical solution to achieve this challenge. These machines can reduce the cycle time and increase the productivity. For example, parts of last generations motors in the aerospace industry and also lot of mechanical components from the energy industry have increased demands regarding performance and safety. The complexity of components made with high-quality materials require more and more specific manufacturing means.

Milling and turning features implemented in the same machine allow it to turn 3 dimensional components with continuous 5-axis thanks to angular A axis (cradle) and C axis of the machine.

Thanks to the unique electromagnetic design which has a very robust and reliable rotor, made with encapsulated magnets inserted in the lamination stack, the ETEL TMK motors redefine the torque motor concept. It is able to reach speed levels up to 8 times higher than typical motors, with the same footprint. With a continuous torque value 30% higher than standard motors, the TMKs do not make any compromise of its primary fonction: provide high torque at low speed.



Picture courtesy of RGI France SAS

ETEL torque motors in 2-axis milling heads

ETEL started to develop direct drive motors to serve industry. It took a few years to convince the machine tool industry that direct drive torque motors were the solution for their future needs.

ETEL, being the first supplier of torque motors, set what became the standards in terms of dimensions and performance. At that time, this very fast evolution of direct drives in machine tools was lead by the most renowned European machine tool makers.

Today, machine tool makers are present all over the globe and are becoming stronger in Asian countries as well as in the USA for instance. ETEL responded to these emerging markets by opening offices in these countries to provide the best possible local support and collaborated in the very early phases of new machine development.

These 2-axis head machines were developed with ETEL's TMB+ motors which can meet the most demanding specifications in diverse applications including aerospace, die and mold, energy and automotive markets. By using direct drive TMB+ motors in both A and C axes, components can be machined with the highest level of precision and surface qualities. In addition, the 2-axis head machines benefit from the quality and reliability of ETEL products and can proudly compete with the most advanced European 2-axis heads.



Picture courtesy of Setco Spindles Company Ltd.

ETEL is part of a historic achievement



Addressing new technological challenges that push the limits of the impossible has always been a source of ETEL's inspiration and innovation. Today ETEL is proud of its contribution to the Solar Impulse project that combines the most advanced scientific knowledge in terms of aeronautics, materials, photovoltaic energy and electrical motors. What used to be a dream is now a great success that will certainly open doors to major steps in aeronautics. Flying days and nights without fuel is now proven to be achievable.

ETEL torque motors powered the ultra-lightweight revolutionary airplane for more than 500 hours of flying around the globe in the most demanding environmental conditions. The torque motors and all other components had to work from ground temperatures to extreme conditions at more than 8000 meters altitude

(~26'000 feet) without any compromise or uncertainty of their performance and reliability. Alongside the incredible human challenge that the pilots faced during the record-breaking flight times, ETEL torque motors operated safely ensuring their safety and contributed to the success of this incredible challenge.



The ETEL torque motors that powered Solar Impulse 1 & 2 are based on the same technology as the parts every ETEL customer receives. The heart of the motor and its magnetic technology is currently ensuring the proper operation of thousands of machines around the world.



© Solar Impulse / Jean Revillard



HEADQUARTERS

ETEL S.A.

Zone Industrielle
CH - 2112 Môtiers
Switzerland
T +41 (0)32 862 01 00
F +41 (0)32 862 01 01
etel@etel.ch · www.etel.ch

GROUP SUBSIDIARIES AND SALES OFFICES

AMERICAS • sales@heidenhain.com
CHINA • china@etel.ch
CZECH REPUBLIC • heidenhain@heidenhain.cz
FRANCE • sales@heidenhain.fr
GERMANY • tbsw.etel@heidenhain.de
GREAT BRITAIN • sales@heidenhain.co.uk
HONG KONG • china@etel.ch
ITALY • etel@etelsa.it
KOREA • etelsales@heidenhain.co.kr
SINGAPORE • info@heidenhain.com.sg
SWITZERLAND • sales@etelsa.ch
TAIWAN • info@heidenhain.tw
THE NETHERLANDS • info@heidenhain.nl

OTHER COUNTRIES • internationalsales@etel.ch

REPRESENTATIVES

ISRAEL • comotech@medital.co.il
SPAIN • farresa@farresa.es

ETEL